

Glammor®

VAC KING



WET & DRY VACUUM CLEANERS

MODEL NO: CCVAC20P & CVAC20PR2

PART NO: 6471100 & 6471127

OPERATING & MAINTENANCE INSTRUCTIONS



ORIGINAL INSTRUCTIONS

GC01/23 - rev 14

INTRODUCTION

Thank you for selecting this VAC KING Vacuum Cleaner, which will provide you with a cleaner and safer working environment.

This machine is capable of collecting both wet and dry materials as well as water. DO NOT, however, collect any other type of liquid as this could be dangerous.

Before attempting to operate the machine, it is essential that you read this manual thoroughly and carefully follow all instructions given. In doing so you will ensure the safety of yourself and that of others around you, and you can also look forward to the machine giving you long and satisfactory service.

This appliance is not intended for use by persons (including children) with reduced physical, sensory or mental capabilities, or lack of experience and knowledge, unless they have been given supervision or instruction concerning use of the appliance by a person responsible for their safety. Children should be supervised to ensure that they do not play with the appliance.

GUARANTEE

This CLARKE product is guaranteed against faulty manufacture for a period of 12 months from the date of purchase. Please keep your receipt as proof of purchase.

This guarantee is invalid if the product is found to have been abused or tampered with in any way, or not used for its intended purpose.

Faulty goods should be returned to their place of purchase, no product can be returned to us without prior permission.

This guarantee does not effect your statutory rights.

ENVIRONMENTAL PROTECTION



By purchasing this product, the customer is taking on the obligation to deal with its safe disposal in accordance with the Waste Electrical and Electronic Equipment regulations (WEEE).

In effect, this means that this product must not be disposed of with general household waste. It must be disposed of according to the laws governing Waste Electrical and Electronic Equipment (WEEE) at a recognised disposal facility.

SAFETY PRECAUTIONS

WORK AREA

1. Avoid operating in the presence of flammable liquids or gases. The motor may produce sparks during operation. Do not use in enclosed areas where flammable, explosive or toxic vapours are given off.

PERSONAL SAFETY

1. Always stay alert, watch what you are doing and use common sense when operating the CVAC. Do not use the CVAC while you are tired or under the influence of medication, drugs or alcohol. A moment of inattention can result in personal injury.
2. Never over-reach. Keep your proper footing and balance at all times to enable better control of the machine in unexpected situations.
3. Always store the machine out of reach of children.

GENERAL MACHINE USE AND CARE

1. Prior to use, all users should become familiar with this instruction booklet.
2. Always maintain the CVAC with care and keep it clean for best / safest performance.
3. Never use this CVAC if any part is damaged. Have it inspected and repaired by your Clarke dealer. Do not use if the electric cable, plug, or the machine itself, is in poor condition.
4. Never abuse the power cable. Never pull on the cable when removing the plug from the socket or lift the machine by the power cable. Take care not to close doors on the cable, or allow it to become snagged under furniture/objects with sharp edges. Keep away from heat or oil.
5. Only use extension leads that are of an appropriate power rating and suitable for the work environment. Extension leads must have an earth connection. Inspect the extension lead regularly and replace if damaged.
6. Always take care when a long hose is required in the work area as it presents a trip hazard. Tidy the hose away when the job is finished.
7. Never pick up flammable or readily combustible material such as hot ashes or coals, or use in the presence of explosive liquids or vapours.
8. Never pick up burning cigarettes or other smoking substances.
9. Never abuse the CVAC by standing on it.
10. Always transport the CVAC by lifting it by the handle.

CARE & STORAGE

1. When not in use, turn off by the On/Off switch on top of the machine, then remove the plug from the mains power supply.
2. When you have finished with the machine, ensure the electric cable is stowed away and not left as a hazard for others to trip over.
3. Do not change filters, or carry out any cleaning or servicing, without first disconnecting the machine from the power supply.
4. Keep the external surfaces clean. Avoid impact damage and do not allow the machine to come into contact with abrasive or corrosive materials.
5. Do not use solvents, thinners or alcohol to clean the CVAC, as these chemicals will damage the finish. With the machine unplugged from the power supply, use a dry cloth to wipe over the plastic casing.
6. When not in use the CVAC should be stored in a secure, dry place, out of the reach of children. DO NOT leave it exposed to the elements and avoid direct sunlight, direct heat, rain/moisture etc.
7. Only use parts and accessories recommended in this manual. The use of unauthorised accessories or attachments is not permitted and may result in personal injury or damage to the machine.
8. Do not attempt to repair or modify the machine. Do not attempt any electrical repair yourself. Consult a qualified electrician or our Service Department on 020 8988 7400.

ELECTRICAL CONNECTIONS



WARNING! READ THESE ELECTRICAL SAFETY INSTRUCTIONS THOROUGHLY BEFORE CONNECTING THE PRODUCT TO THE MAINS SUPPLY.

Before switching the product on, make sure that the voltage of your electricity supply is the same as that indicated on the rating plate. This product is designed to operate on 230VAC 50Hz. Connecting it to any other power source may cause damage.

This product may be fitted with a non-rewireable plug. If it is necessary to change the fuse in the plug, the fuse cover must be refitted. If the fuse cover becomes lost or damaged, the plug must not be used until a suitable replacement is obtained.

If the plug has to be changed because it is not suitable for your socket, or due to damage, it should be cut off and a replacement fitted, following the wiring instructions shown below. The old plug must be disposed of safely, as insertion into a mains socket could cause an electrical hazard.

CVAC20P (DOUBLE INSULATED APPLIANCE)



WARNING! THIS PRODUCT IS DOUBLE INSULATED. THE WIRES IN THE POWER CABLE ARE COLOURED IN ACCORDANCE WITH THE FOLLOWING CODE: Blue = Neutral Brown = Live

If the colours of the wires in the power cable of this product do not correspond with the markings on the terminals of your plug, proceed as follows.

- The **Blue** wire must be connected to the terminal marked **N** or coloured **Black**.
- The **Brown** wire must be connected to the terminal marked **L** or coloured **Red**

Plug must be BS1363/A approved.

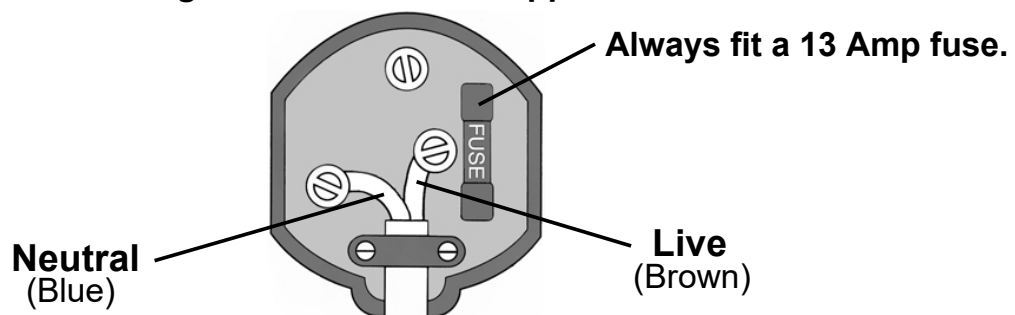

Ensure that the outer sheath of the cable is firmly held by the clamp

We strongly recommend that this machine is connected to the mains supply via a Residual Current Device (RCD).

CVAC20PR2 (EARTHED ELECTRICAL APPLIANCE)



**WARNING! THE WIRES IN THE POWER CABLE OF THIS PRODUCT ARE COLOURED IN ACCORDANCE WITH THE FOLLOWING CODE:
Blue = Neutral Brown = Live Yellow and Green = Earth**

If the colours of the wires in the power cable of this product do not correspond with the markings on the terminals of your plug, proceed as follows.

- The **Blue** wire must be connected to the terminal which is marked **N** or coloured **Black**.
- The **Brown** wire must be connected to the terminal which is marked **L** or coloured **Red**.
- The **Yellow and Green** wire must be connected to the terminal marked **E** or  or coloured **Green**.

Plug must be BS1363/A approved.

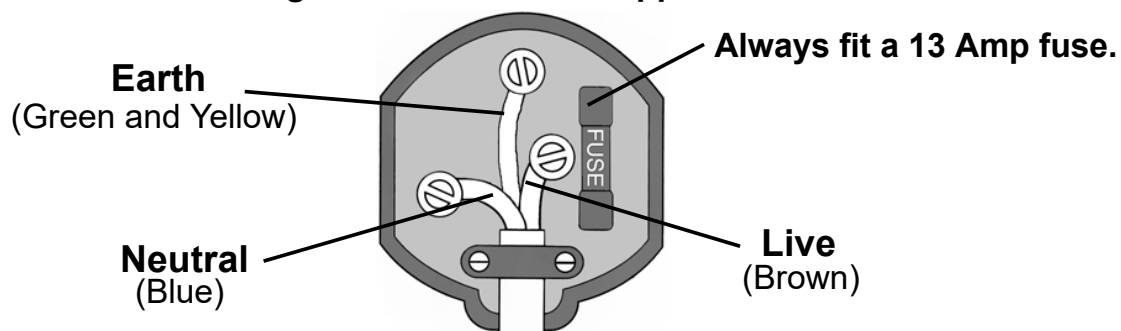

Ensure that the outer sheath of the cable is firmly held by the clamp

We strongly recommend that this machine is connected to the mains supply via a Residual Current Device (RCD).

If in any doubt, consult a qualified electrician. DO NOT attempt any repairs yourself.

COMPONENTS

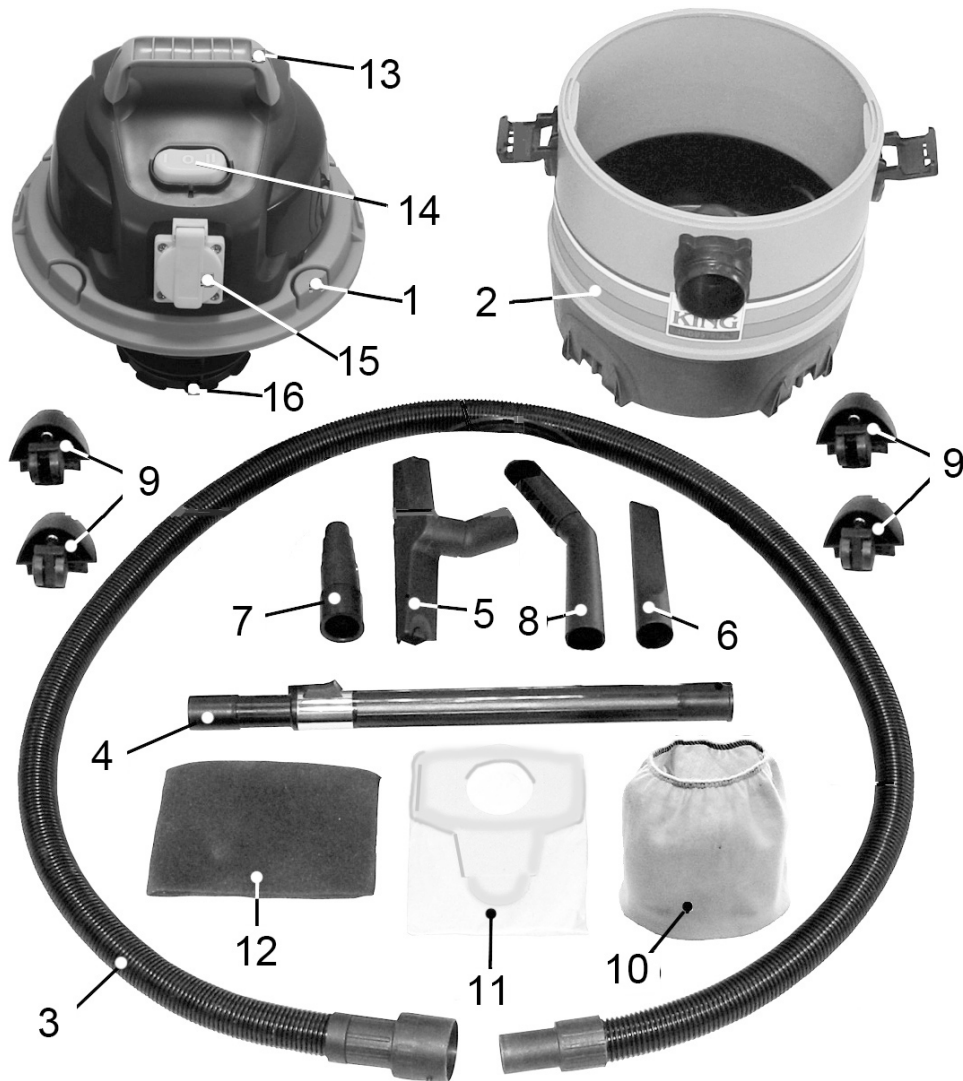

No	Description	No	Description
1	Motor Housing & Head Section	9	Caster
2	Container	10	Linen Bag Filter
3	Flexible Hose	11	Paper Dust Bag
4	Extension Tube	12	Foam Filter (water pick-up only)
5	Brush Adaptor	13	Handle
6	Crevice Tool	14	ON/OFF Switch
7	Power Tool Adaptor (20PR2 only)	15	Auxiliary Power Take-Off (20PR2)
8	Angle Adaptor	16	Filter Cage

PREPARATION FOR USE



WARNING: BEFORE USING THE CVAC, MAKE SURE THAT YOU HAVE READ AND UNDERSTOOD THE SAFETY INSTRUCTIONS

UNPACKING & ASSEMBLY

With the CVAC removed from the packaging, undo the two clamps securing the head and remove the components from within the tank. Lay them out and check for shortages and that no damage was suffered in transit.

CASTORS

For ease of mobility, the CVAC base is provided with castors which require assembling. Push the four castors onto their mountings firmly. Four self-tapping screws are provided which should be screwed into the caster mounting to secure it to the unit. Attach the CVAC 20PR2 handle to the head section using the screws provided.

THE FILTERS

Filters are essential to ensure that dust or foreign matter does not enter the motor compartment which would reduce motor efficiency, and eventually cause serious damage.

During dry operation, the double filtering action of the linen and paper bag filters protects the motor from dust and dirt but also ensures that the cleanest possible air is exhausted, thereby preventing dust being spread into the environment.

- A. Foam Filter
- B. Linen Bag Filter
- C. Paper Bag Filter



A.



B.



C.

FOR WET USE

The Foam Filter is only to be used for picking up water.

It is the only filter used during this operation and must be fitted over the filter cage as shown.

The linen and paper bag filters must be removed before using the CVAC to pick up water.



FOR DRY USE

The Linen Bag Filter must be fitted over the filter cage and is used when dry vacuuming ONLY.

Remove the foam filter for dry use.

The Paper Bag Filter should be used in conjunction with the Linen Bag filter for dry vacuuming ONLY. It is fitted over the inlet elbow on the inside of the container. The paper bag filter will inflate in use and dust is being collected.



OPERATING INSTRUCTIONS

Before use, open the machine and check that the appropriate filters are fitted and are in good condition. If the paper bag is full, replace it. Spare bags are available from your Clarke stockist.

Switch the machine on and begin work. The CVAC should be positioned on a firm, level surface. Do not cover the CVAC and always position it with good ventilation. The CVAC must remain upright, especially when picking up water.

When moving the CVAC;

- Always use the handle.
- Do not lift by (or place a strain on) the hose or cable.
- When finished, always switch off & disconnect from the power supply.

REMEMBER to use the FOAM FILTER ONLY for picking up WATER and ensure that it is correctly fitted so that it covers the filter cage completely.

NOTE: Be aware that when picking up water, the tank will gradually fill up. Check and empty at frequent intervals, otherwise the float located within the filter cage will rise and eventually shut off the suction. This is a safety feature to prevent water from coming into contact with electrical components. Should suction stop, you will hear a more urgent sound from the motor. Immediately switch OFF and empty the tank, otherwise the motor could overheat.

CVAC20PR2 ONLY

This machine is provided with a standard three pin auxiliary power take off which enables the machine to be used as a dust extractor for power tools. Plug the power tool into the socket and switched it on by setting the rocker switch to the position indicated with two bars.

The CVAC will automatically start. When the power tool is switched off, the CVAC will switch itself off after a short delay. Any power tool up to a maximum of 1400W/6A can be used.

A stepped adapter tube is provided which may be pushed into the dust extract port of any suitable power tool and on to which, the flexible hose may be attached.

By connecting the flexible hose to the exhaust of the CVAC, a blower function can be achieved.



Always clear the hose of any obstructions before attaching to the blower port.

WARNING: ALWAYS WEAR EYE PROTECTION TO PREVENT DEBRIS FROM BEING BLOWN OR RICOCHETING INTO THE EYES OR FACE WHICH COULD RESULT IN SERIOUS INJURY.

MAINTENANCE

Maintenance is limited to inspecting the filters and replacing when necessary. If the filters become holed or damaged they must be replaced.

The cartridge filter is of paper construction and therefore may not be washed. It may be brushed clean and compressed air set at a low pressure may also be used. The linen bag may be washed as required and dried before use.

Ensure the hose is kept in good condition. A damaged hose will seriously effect the efficiency of the machine and should be replaced immediately.

Inspect all other components periodically and replace damaged castors or accessories when necessary. Contact your CLARKE dealer for replacements.

Regular inspection and the correct maintenance of the filters will ensure efficient running and prolong the life of your machine.

SPARE PARTS

	CVAC20P	CVAC20PR2
LINEN BAG FILTER	6471090	6471090
PAPER DUST BAG FILTER	6471094	6471094
FOAM FILTER	6471092	6471092
CASTER	TVQTJC0400	YVQTJL0100A
FLEXIBLE HOSE 2.5 M	HT80819	HT80819
ANGLE ADAPTOR (HOSE TO TUBE)	HT80401	HT80401A
METAL EXTENSION TUBE	HT80903	HT80903A
COMBI BRUSH ADAPTOR TOOL	HT80710	HT80710A
CREVICE TOOL	HT80707	HT80707A
POWER TOOL ADAPTOR	N/A	HT80302A
OPTIONAL 5M HOSE	6471155	6471157
20L DUST BAG	6471135	6471135

SPARE PARTS

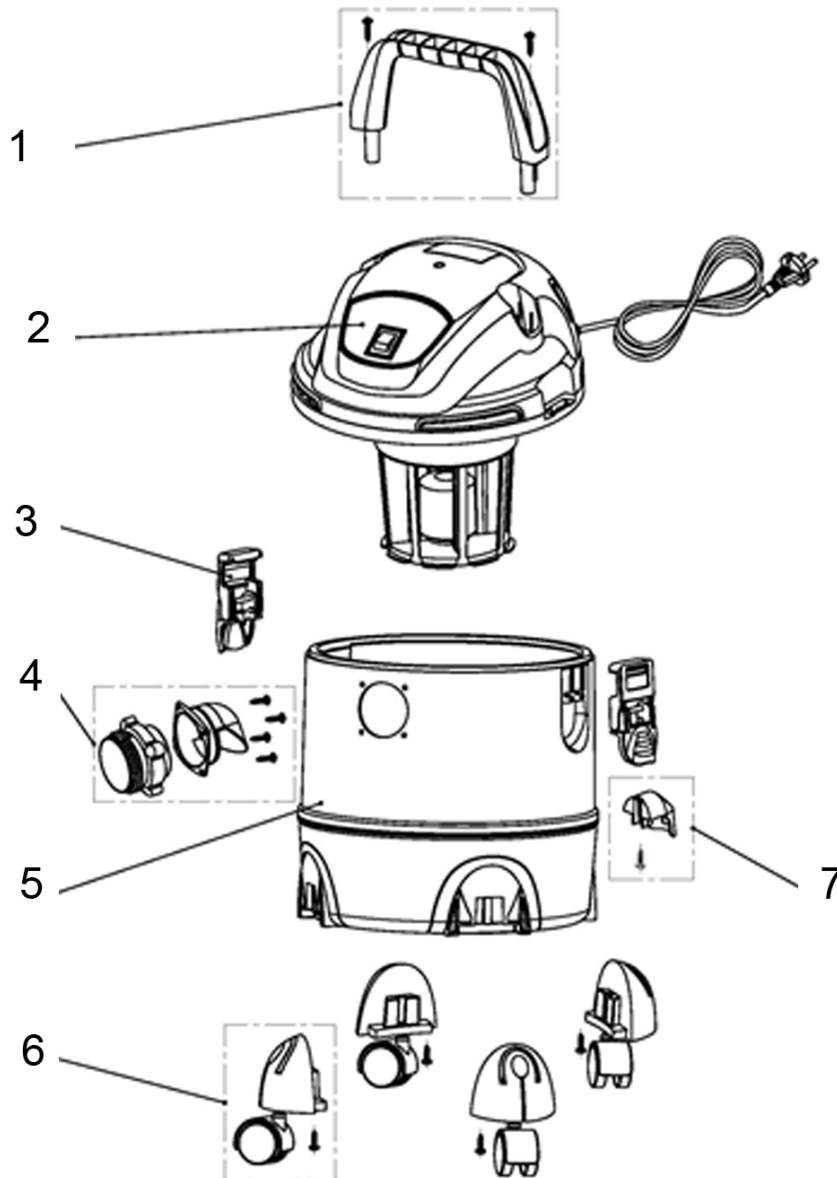

No	DESCRIPTION
1	Handle
2	Head Assembly
3	Latch Assembly
4.	Hose Inlet Assembly

No	DESCRIPTION
5	Container Body
6	Castor Assembly
7	Water Drain Assembly

SPECIFICATION

MODEL	CVAC20P	CVAC20PR2
Part No	6471100	6471127
Weight	5 kg	5.9 kg
Dimensions (L x W x H) mm	446 x 446 x 522	340 x 315 x 510
Tank Capacity (water)	13 Litres	12 Litres
Dust Capacity	17 Litres	14 Litres
Max Vacuum	16.5 kPa	16.5 kPa
Max Airflow	30L/sec	32L/sec
Duty Cycle	S1(continuous)	
Fuse Rating	13 Amps	
Power Supply	230 V/50Hz/1ph	
Motor Power rating	1.25 kW	1.4 kW
IP Rating	IP24	
Output Socket Rating		1400 W (6A)
Sound Pressure Level (@2m)	82 dB LpA	

Please note that the details and specifications contained herein, are correct at the time of going to print. However, CLARKE International reserve the right to change specifications at any time without prior notice.

DECLARATION OF CONFORMITY - CVAC20P



Hemnoll Street, Epping, Essex CM11 6 4LG

DECLARATION OF CONFORMITY

This is an important document and should be retained.

We hereby declare that this product(s) complies with the following statutory requirement(s):

Electromagnetic Compatibility Regulations 2016
Electrical Equipment (Safety) Regulations 2016
The Restriction of the Use of Certain Hazardous Substances in Electrical and Electronic Equipment Regulations 2012

The following standards have been applied to the product(s):

EN IEC 55014-1:2021, EN IEC 55014-2:2021, EN IEC 61000-3-2:2019/A1:2021,
EN 61000-3-3:2013/A1:2019, EN 60335-2-2:2010/A1:2013, EN 60335-1:2012/A15:2021,
EN 62233:2008

The technical documentation required to demonstrate that the product(s) meet(s) the requirement(s) of the aforementioned legislation has been compiled and is available for inspection by the relevant enforcement authorities.

The UKCA mark was first applied in: 2021

Product Description: Vacuum Cleaner
Model number(s): CVAC20P
Serial / batch Number: N/A
Date of issue: 04/01/2023

Signed:

J.A. Clarke
Director



Fitzwilliam Hall, Fitzwilliam Place, Dublin 2

DECLARATION OF CONFORMITY

This is an important document and should be retained.

We hereby declare that this product(s) complies with the following directive(s):

2014/30/EU *Electromagnetic Compatibility Directive*
2014/35/EU *Low Voltage Directive*
2011/65/EU *RoHS (Restriction of Hazardous Substances) Directive*

The following standards have been applied to the product(s):

EN IEC 55014-1:2021, EN IEC 55014-2:2021, EN IEC 61000-3-2:2019/A1:2021,
EN 61000-3-3:2013/A1:2019, EN 60335-2-2:2010/A1:2013, EN 60335-1:2012/A15:2021,
EN 62233:2008

The technical documentation required to demonstrate that the product(s) meet(s) the requirement(s) of the aforementioned directive(s) has been compiled and is available for inspection by the relevant enforcement authorities.

The CE mark was first applied in: 2009

Product Description: Vacuum Cleaner
Model number(s): CVAC20P
Serial / batch Number: N/A
Date of issue: 04/01/2023

Signed:

J.A. Clarke
Director

DECLARATION OF CONFORMITY - CVAC20PR2



Hennell Street, Epping, Essex CM16 4LG

DECLARATION OF CONFORMITY

This is an important document and should be retained.

We hereby declare that this product(s) complies with the following statutory requirement(s):

Electromagnetic Compatibility Regulations 2016
Electrical Equipment (Safety) Regulations 2016
The Restriction of the Use of Certain Hazardous Substances in Electrical and Electronic Equipment Regulations 2012

The following standards have been applied to the product(s):

EN IEC 55014-1:2021, EN IEC 55014-2:2021, EN IEC 61000-3-2:2019/A1:2021,
EN 61000-3-3:2013/A2:2021, EN 60335-2-2:2010/A1:2013, EN 60335-1:2012/A15:2021,
EN 62233:2008

The technical documentation required to demonstrate that the product(s) meet(s) the requirement(s) of the aforementioned legislation has been compiled and is available for inspection by the relevant enforcement authorities.

The UKCA mark was first applied in: 2021

Product Description: Vacuum Cleaner

Model number(s): CVAC20PR2

Serial / batch Number: N/A

Date of Issue: 04/01/2023

Signed:

J.A. Clarke
Director



Fitzwilliam Hall, Fitzwilliam Place, Dublin 2

DECLARATION OF CONFORMITY

This is an important document and should be retained.

We hereby declare that this product(s) complies with the following directive(s):

2014/30/EU *Electromagnetic Compatibility Directive*
2014/35/EU *Low Voltage Directive*
2011/65/EU *RoHS (Restriction of Hazardous Substances) Directive*

The following standards have been applied to the product(s):

EN IEC 55014-1:2021, EN IEC 55014-2:2021, EN IEC 61000-3-2:2019/A1:2021,
EN 61000-3-3:2013/A2:2021, EN 60335-2-2:2010/A1:2013, EN 60335-1:2012/A15:2021,
EN 62233:2008

The technical documentation required to demonstrate that the product(s) meet(s) the requirement(s) of the aforementioned directive(s) has been compiled and is available for inspection by the relevant enforcement authorities.

The CE mark was first applied in: 2009

Product Description: Vacuum Cleaner

Model number(s): CVAC20PR2

Serial / batch Number: N/A

Date of Issue: 04/01/2023

Signed:

J.A. Clarke
Director

A SELECTION FROM THE VAST RANGE OF

Clarke®

QUALITY PRODUCTS



AIR COMPRESSORS
From DIY to industrial, Plus air tools, spray guns and accessories.

GENERATORS
Prime duty or emergency standby for business, home and leisure.

POWER WASHERS
Hot and cold, electric and engine driven - we have what you need

WELDERS
Mig, Arc, Tig and Spot. From DIY to auto/industrial.

METALWORKING
Drills, grinders and saws for DIY and professional use.

WOODWORKING
Saws, sanders, lathes, mortisers and dust extraction.

HYDRAULICS
Cranes, body repair kits, transmission jacks for all types of workshop use.

WATER PUMPS
Submersible, electric and engine driven for DIY, agriculture and industry.

POWERTOOLS
Angle grinders, cordless drill sets, saws and sanders.

STARTERS/CHARGERS
All sizes for car and commercial use.



PARTS & SERVICE: 0208 988 7400

Parts Enquiries
Parts@clarkeinternational.com

Servicing & Technical Enquiries
Service@clarkeinternational.com

SALES: UK 01992 565333 or Export 00 44 (0)1992 565335

Clarke® INTERNATIONAL Hemnall Street, Epping, Essex CM16 4LG
www.clarkeinternational.com